

INSTALLATION INSTRUCTIONS

Model: **PS**
Fixture Family: **Remote LED Driver**
Document Description: Installation Instructions for
Remote LED Driver

1717 West Civic Drive Milwaukee, WI 53209
414-354-6600
Design Modification Rights Reserved
© Visa Lighting

SINGLE COLOR – one channel

1. Remove Cover by removing the (4) Cover Screws.
2. Mount Remote Box in an accessible, un-insulated area with free air flow. Use fasteners appropriate for the mounting surface (not included).

WARNING!

Connect line voltage in the Line Voltage Compartment only.
Connect low voltage in the Low Voltage Compartment only.

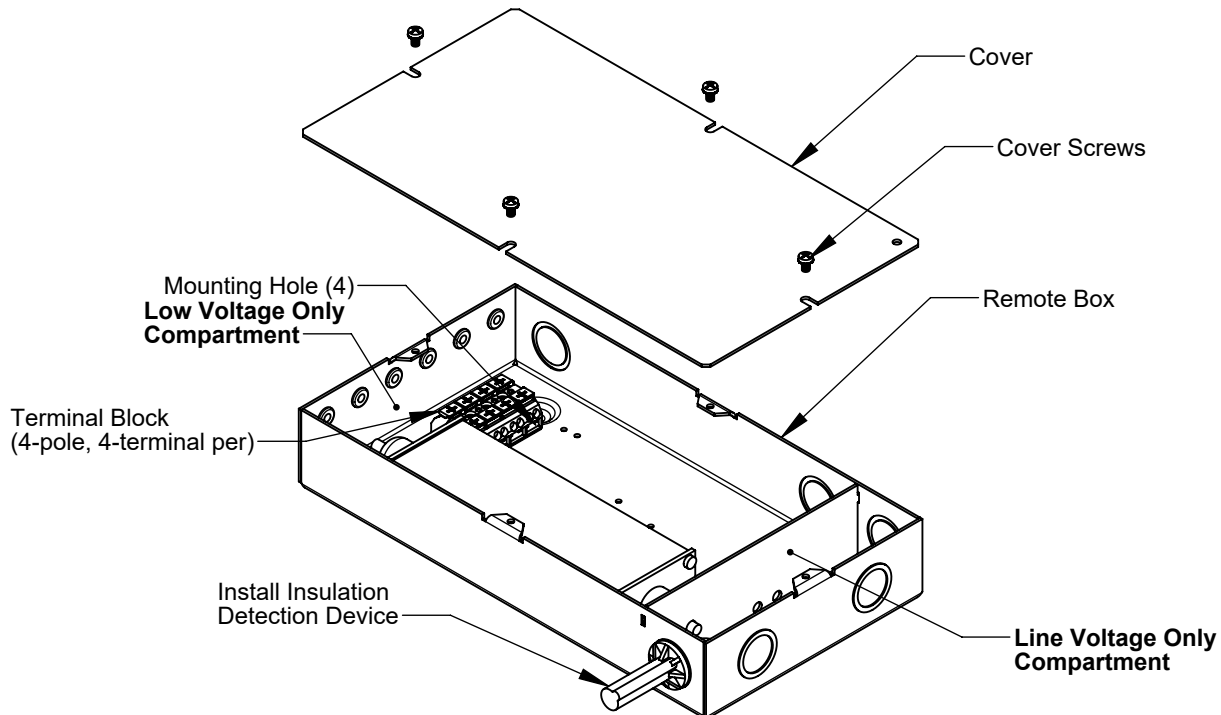

CAUTION – DOUBLE CHECK ALL CONNECTIONS BEFORE APPLYING POWER! MISCONNECTIONS WILL DAMAGE COMPONENTS!

- 1 Make low voltage (24VDC) connections to terminal block by pressing top of block and inserting appropriate wire. BE SURE TO OBSERVE PROPER POLARITY!
- 2 If included, install the insulation detection device into the knockout.
- 3 Make line voltage connections.
- 4 Replace Cover and Cover Screws

Drawing: 761962XX

Rev: C

Sheet: 1 of 4

Eng: JME

Date Drawn: 06/30/2010

When using electrical equipment, basic safety precautions should always be followed, including the following:

- Read all instructions carefully before installing and save for future use.
- Make sure all connections are in accordance with the National Electrical Code and local regulations.
- To avoid possible electric shock, be sure the power supply is turned off before servicing or installing the fixture.
- Service should be performed by qualified personnel.
- These instructions may not cover all details or variations. If additional information is needed, please contact Visa Lighting.

INSTALLATION INSTRUCTIONS

Model: **PS**
Fixture Family: **Remote LED Driver**
Document Description: Installation Instructions for
Remote LED Driver

1717 West Civic Drive Milwaukee, WI 53209
414-354-6600
Design Modification Rights Reserved
© Visa Lighting

RGB COLOR – three channel

1. Remove Cover by removing the (4) Cover Screws.
2. Mount Remote Box in an accessible, un-insulated area with free air flow. Use fasteners appropriate for the mounting surface (not included).

WARNING!

Connect line voltage in the Line Voltage Compartment only.
Connect low voltage in the Low Voltage Compartment only.

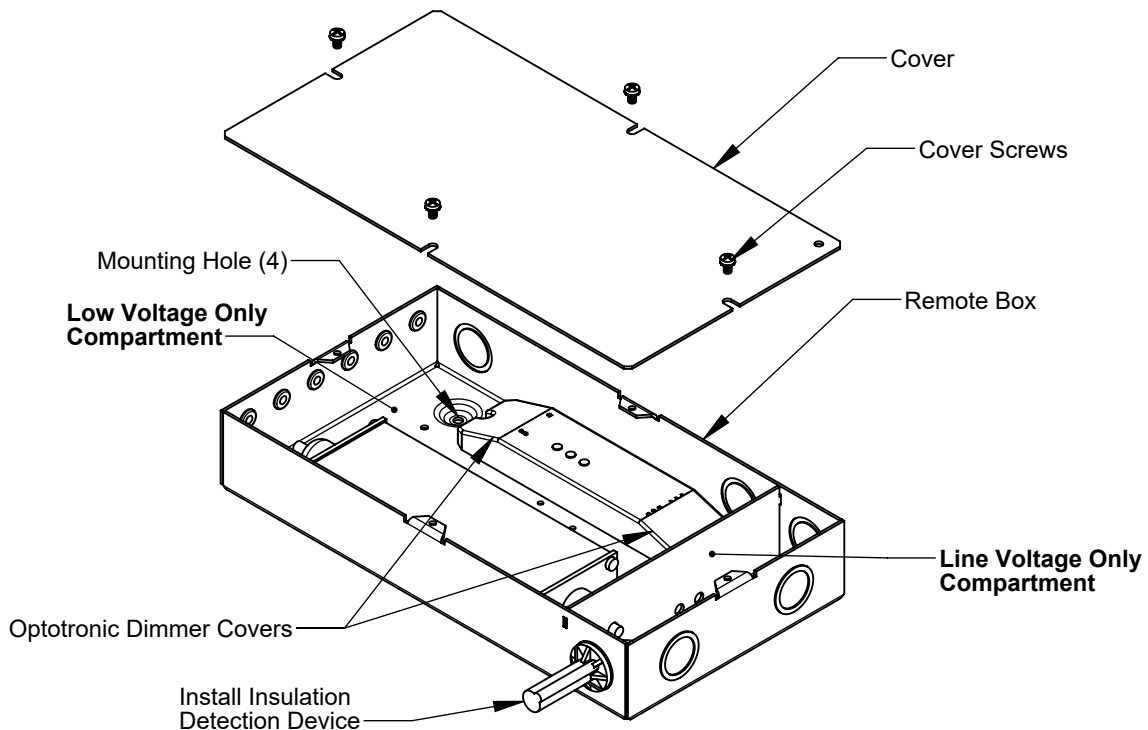

CAUTION – DOUBLE CHECK ALL CONNECTIONS BEFORE APPLYING POWER! MISCONNECTIONS WILL DAMAGE COMPONENTS!

- 1 Remove Optotronic Dimmer Covers by removing screws.
- 2 Make connections to the light fixture using the Outputs to LED Modules as follows:
 - a. + = Black Wire
 - b. R- = Red Wire
 - c. G- = Green Wire
 - d. B- = Blue Wire
- 3 If using multi-conductor cable, cap off any un-used leads.
- 4 Make control connections per control (not included) guidelines.
- 5 If using DMX control (not included), set the DMX start channel using the three dial switches. This unit will use three consecutive DMX channels starting with the set address (e.g. Set = 1 = Red LED, 2 = Green LED, 3 = Blue LED).
- 6 Replace Optotronic Dimmer Covers and screws.
- 7 If included, install the insulation detection device into the knockout.
- 8 Make line voltage connections.
- 9 Replace Cover and Cover Screws

When using electrical equipment, basic safety precautions should always be followed, including the following:

- Read all instructions carefully before installing and save for future use.
- Make sure all connections are in accordance with the National Electrical Code and local regulations.
- To avoid possible electric shock, be sure the power supply is turned off before servicing or installing the fixture.
- Service should be performed by qualified personnel.
- These instructions may not cover all details or variations. If additional information is needed, please contact Visa Lighting.

INSTALLATION INSTRUCTIONS

Model: **PS**
Fixture Family: **Remote LED Driver**
Document Description: Installation Instructions for
Remote LED Driver

1717 West Civic Drive Milwaukee, WI 53209
414-354-6600
Design Modification Rights Reserved
© Visa Lighting

TYPE IC

1. Remove Cover by removing the Cover Screw.
2. Mount remote box in an accessible area per local & national codes, use fasteners appropriate for the mounting surface (by others).
 - a. Mounting Tabs can be bent at 90 degree angle with pliers to attach box to t-grid, or can be bent as needed for mounting
3. Make all wire connections per local & national codes.
4. Re-install Cover with the Cover Screw

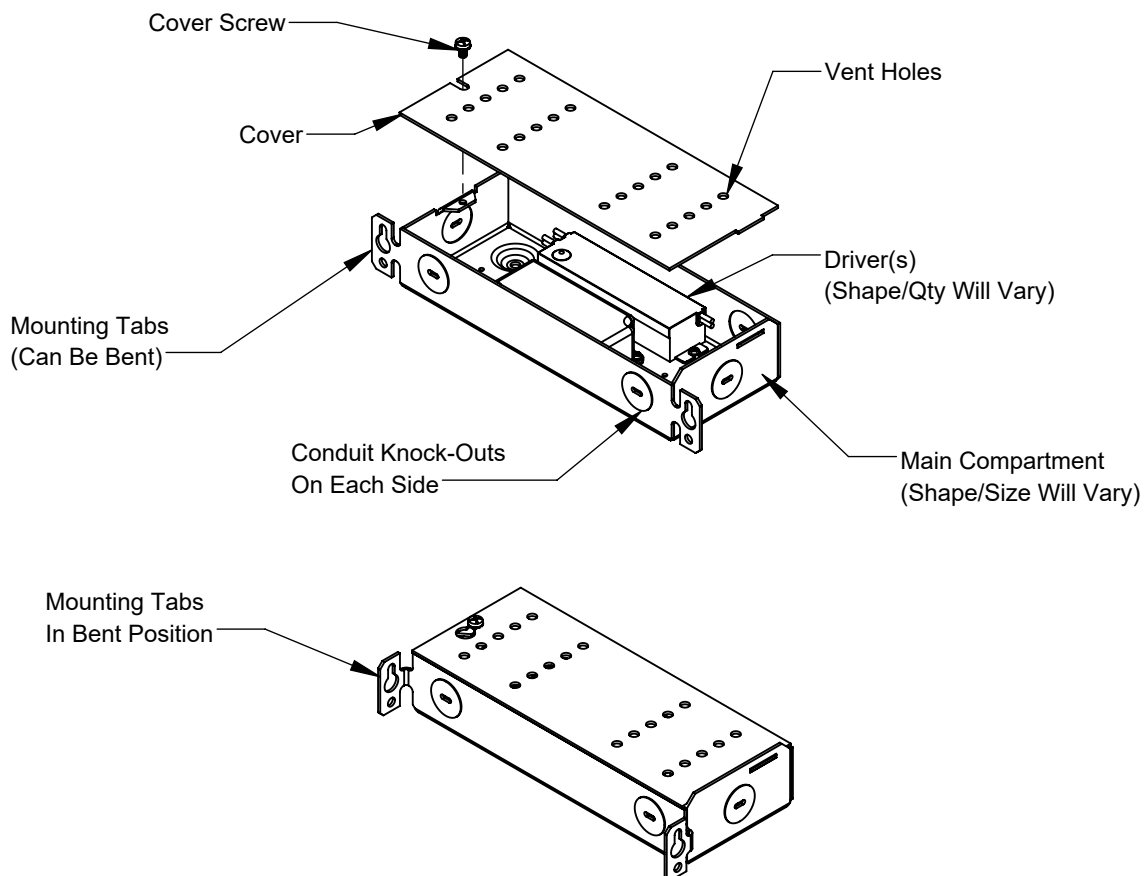

Drawing: 761962XX

Rev: C

Sheet: 3 of 4

Eng: JME

Date Drawn: 06/30/2010

When using electrical equipment, basic safety precautions should always be followed, including the following:

- Read all instructions carefully before installing and save for future use.
- Make sure all connections are in accordance with the National Electrical Code and local regulations.
- To avoid possible electric shock, be sure the power supply is turned off before servicing or installing the fixture.
- Service should be performed by qualified personnel.
- These instructions may not cover all details or variations. If additional information is needed, please contact Visa Lighting.

INSTALLATION INSTRUCTIONS

Model: **PS**
Fixture Family: **Remote LED Driver**
Document Description: Installation Instructions for
Remote LED Driver

1717 West Civic Drive Milwaukee, WI 53209
414-354-6600
Design Modification Rights Reserved
© Visa Lighting

High Wattage

1. Remove Cover by removing the Cover Screws.
2. Mount remote box in an accessible area per local & national codes, use fasteners appropriate for the mounting surface (by others).
3. Make all wire connections per local & national codes.
4. Re-install Cover with the Cover Screws

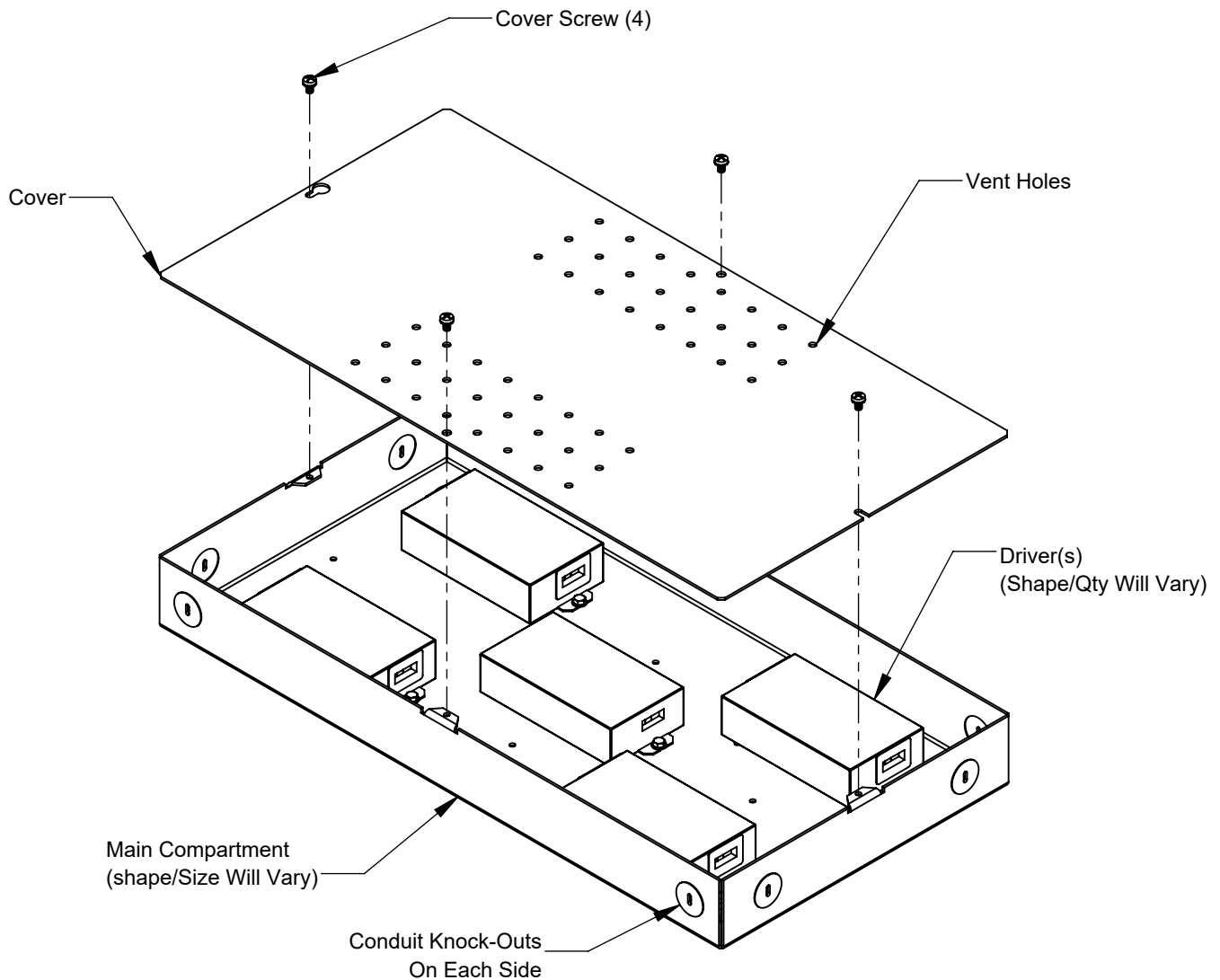

Drawing: 761962XX

Rev: C

Sheet: 4 of 4

Eng: JME

Date Drawn: 06/30/2010

! When using electrical equipment, basic safety precautions should always be followed, including the following:

- Read all instructions carefully before installing and save for future use.
- Make sure all connections are in accordance with the National Electrical Code and local regulations.
- To avoid possible electric shock, be sure the power supply is turned off before servicing or installing the fixture.
- Service should be performed by qualified personnel.
- These instructions may not cover all details or variations. If additional information is needed, please contact Visa Lighting.